

**FINISHED DRAWING**  
 FOR DISCUSSION PURPOSES ONLY  
 SUBJECT TO FURTHER AMENDMENT  
 SIGNED RACHAEL GADD  
 DATE 26-MARCH-2023

REV	DATE	COMMENT	INITIALS
REVA	23/05/22	TENDER ISSUE	CM
REVB	26/03/23	CONSTRUCTION ISSUE	CM

**towongshire**  
*innovation | technology | sustainability*  
 32 TOWONG STREET [PO BOX 55]  
 TALLANGATTA VIC 3700  
 02 6071 5100  
 WWW.TOWONG.VIC.GOV.AU

**TOWONG SHIRE COUNCIL**  
 OMEO\_HIGHWAY  
 MITTA\_MITTA VIC 3701  
 MITTA\_MITTA\_PATHWAYS\_AND\_INFRASTRUCTURE  
 ALIGNMENT\_KEY\_PLAN

DESIGNED	CM	DRAWING NO	
DRAWN	CM	T210809	
CHECKED	RG	SHEET NO	PAGE SIZE
APPROVED	RG	4	A3
SCALE	1:1000		
UNIT	METRES		



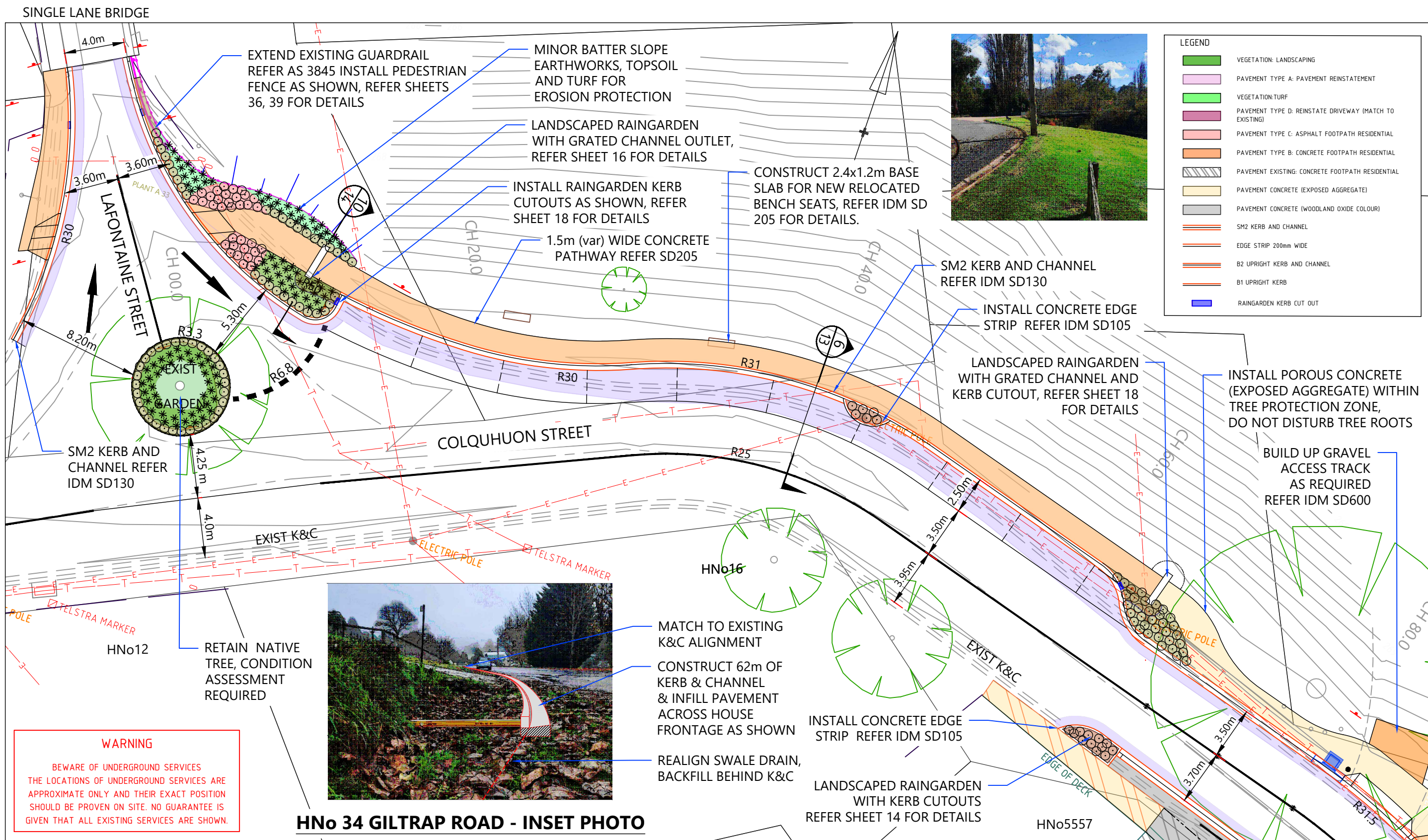

**FINISHED DRAWING**

FOR DISCUSSION PURPOSES ONLY  
SUBJECT TO FURTHER AMENDMENT

SIGNED RACHAEL GADD  
DATE 26-MARCH-2023

REV	DATE	COMMENT	INITIALS
REVA	23/05/22	TENDER ISSUE	CM
REVB	26/03/23	CONSTRUCTION ISSUE	CM

**towongshire**  
Innovation : technology : sustainability

32 TOWONG STREET [PO BOX 55]  
TALLANGATTA VIC 3700  
02 6071 5100  
WWW.TOWONG.VIC.GOV.AU

**TOWONG SHIRE COUNCIL**

OME0\_HIGHWAY  
MITTA\_MITTA VIC 3701

MITTA\_MITTA\_PATHWAYS\_AND\_INFRASTRUCTURE

PLAN\_SHEET\_1\_OF\_6

DESIGNED	CM	DRAWING NO	
DRAWN	CM	T210809	
CHECKED	RG	SHEET NO	PAGE SIZE
APPROVED	RG	5	A3
SCALE	1:250		
UNIT	METRES		



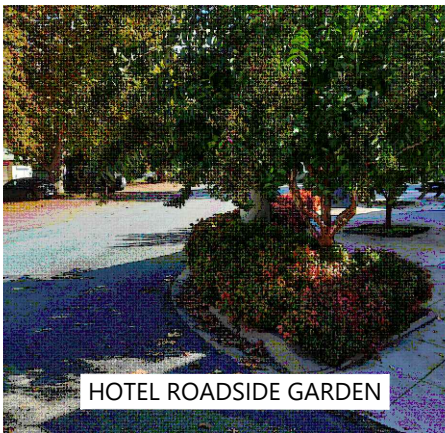
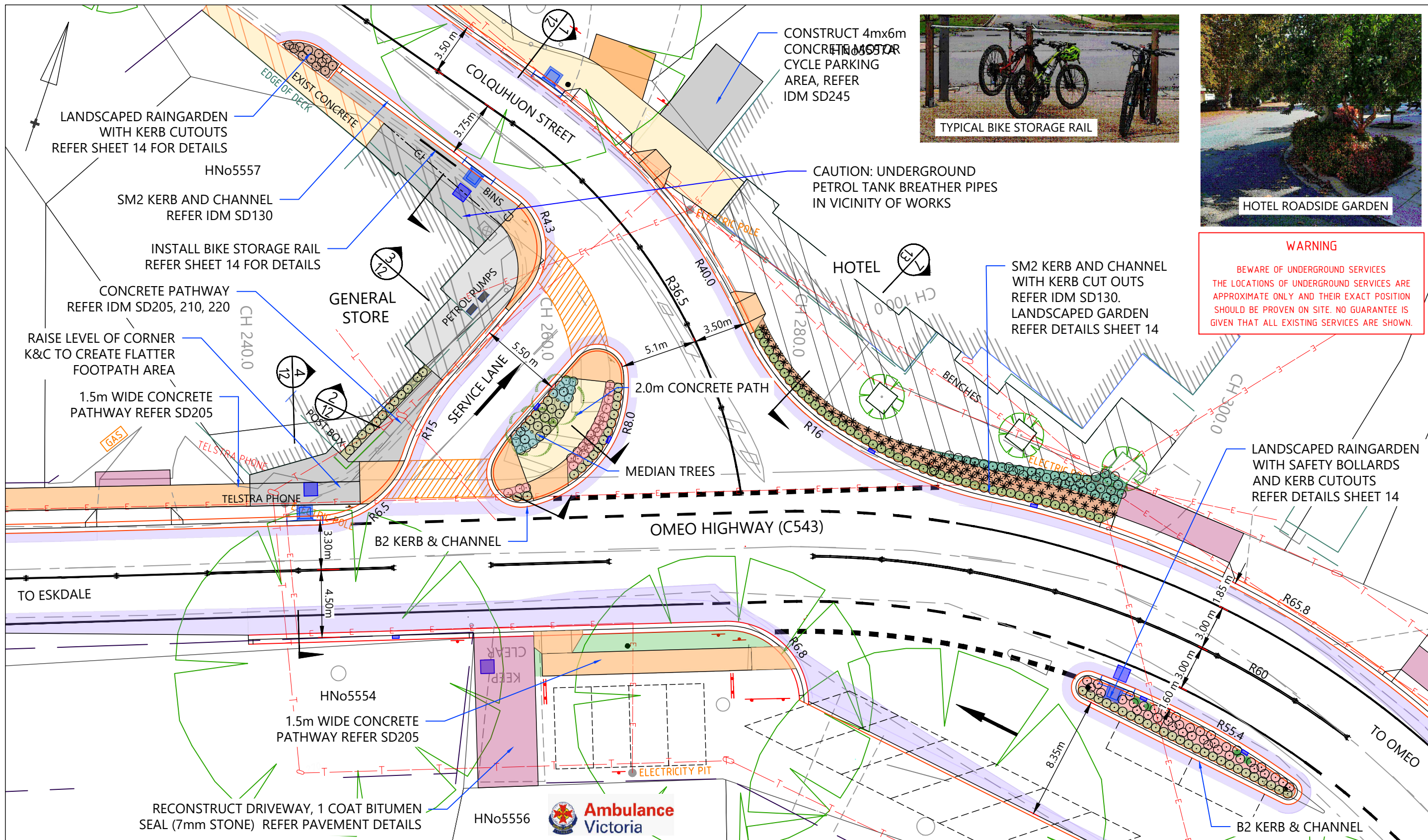

**WARNING**

BWARE OF UNDERGROUND SERVICES  
THE LOCATIONS OF UNDERGROUND SERVICES ARE APPROXIMATE ONLY AND THEIR EXACT POSITION SHOULD BE PROVEN ON SITE. NO GUARANTEE IS GIVEN THAT ALL EXISTING SERVICES ARE SHOWN.

CONSTRUCT 4mx6m CONCRETE MOTOR CYCLE PARKING AREA, REFER IDM SD245

CAUTION: UNDERGROUND PETROL TANK BREATHER PIPES IN VICINITY OF WORKS

SM2 KERB AND CHANNEL WITH KERB CUT OUTS REFER IDM SD130. LANDSCAPED GARDEN REFER DETAILS SHEET 14

LANDSCAPED RAINGARDEN WITH SAFETY BOLLARDS AND KERB CUTOUTS REFER DETAILS SHEET 14

LANDSCAPED RAINGARDEN WITH KERB CUTOUTS REFER SHEET 14 FOR DETAILS

HN0557  
SM2 KERB AND CHANNEL REFER IDM SD130

INSTALL BIKE STORAGE RAIL REFER SHEET 14 FOR DETAILS

CONCRETE PATHWAY REFER IDM SD205, 210, 220

RAISE LEVEL OF CORNER K&C TO CREATE FLATTER FOOTPATH AREA

1.5m WIDE CONCRETE PATHWAY REFER SD205

GENERAL STORE

SERVICE LANE

2.0m CONCRETE PATH

MEDIAN TREES

HOTEL

OMEHO HIGHWAY (C543)

B2 KERB & CHANNEL

TO ESKDALE

HN0554

1.5m WIDE CONCRETE PATHWAY REFER SD205

RECONSTRUCT DRIVEWAY, 1 COAT BITUMEN SEAL (7mm STONE) REFER PAVEMENT DETAILS

HN0556



**FINISHED DRAWING**

FOR DISCUSSION PURPOSES ONLY  
SUBJECT TO FURTHER AMENDMENT

SIGNED RACHAEL GADD  
DATE 26-MARCH-2023

REV	DATE	COMMENT	INITIALS
REVA	23/05/22	TENDER ISSUE	CM
REVB	26/03/23	CONSTRUCTION ISSUE	CM

**towongshire**  
Innovation : technology : sustainability

32 TOWONG STREET [PO BOX 55]  
TALLANGATTA VIC 3700  
02 6071 5100  
WWW.TOWONG.VIC.GOV.AU

**TOWONG SHIRE COUNCIL**

OMEHO\_HIGHWAY  
MITTA\_MITTA VIC 3701

MITTA\_MITTA\_PATHWAYS\_AND\_INFRASTRUCTURE

PLAN\_SHEET\_2\_OF\_6

DESIGNED		CM	DRAWING NO	
DRAWN		CM	T210809	
CHECKED		RG		
APPROVED		RG	SHEET NO	PAGE SIZE
		SCALE 1:250	6	A3
		UNIT METRES		

DYBD REQUIRED BEFORE ALL WORKS COMMENCE



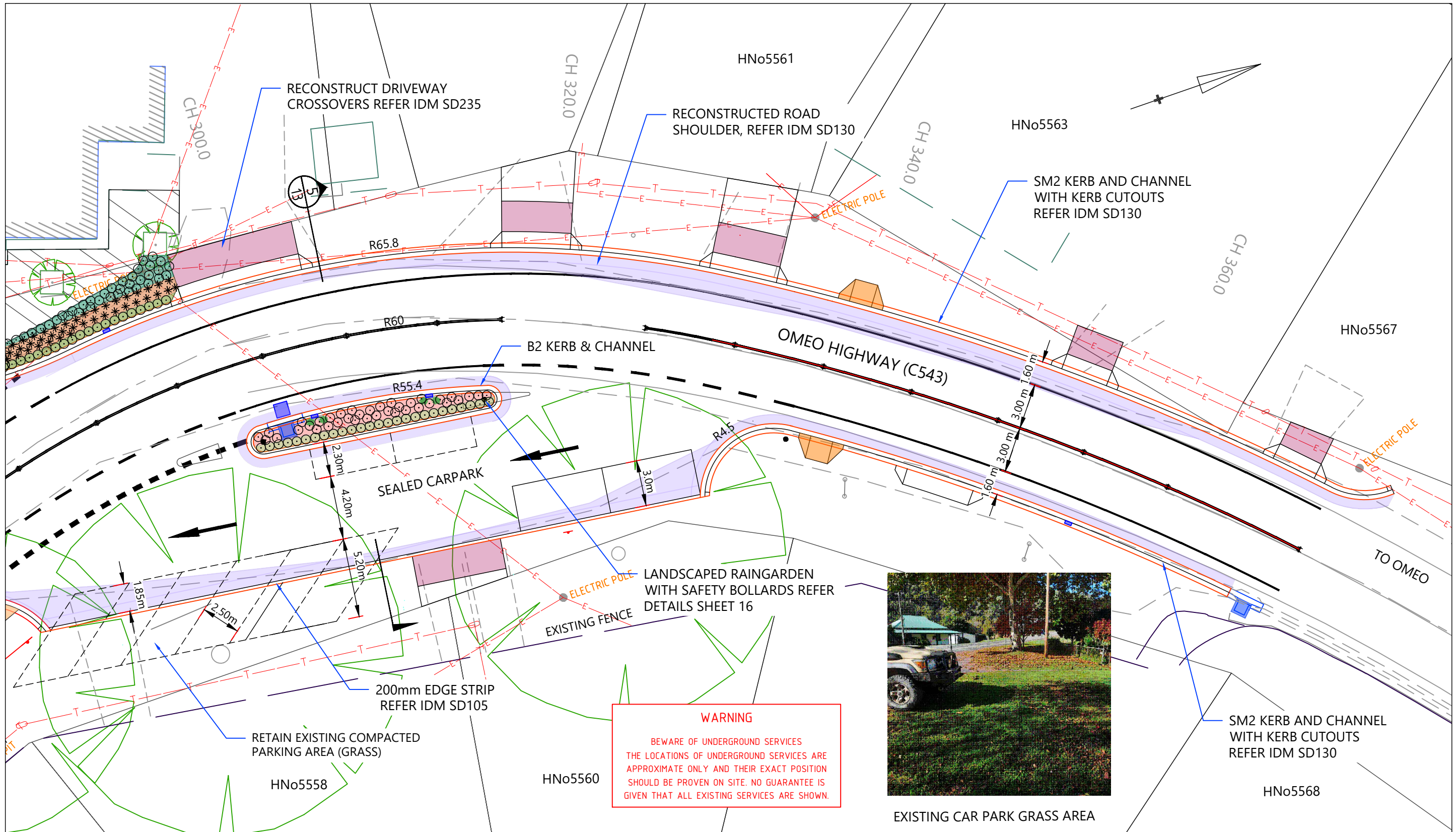

**WARNING**  
 BEWARE OF UNDERGROUND SERVICES  
 THE LOCATIONS OF UNDERGROUND SERVICES ARE APPROXIMATE ONLY AND THEIR EXACT POSITION SHOULD BE PROVEN ON SITE. NO GUARANTEE IS GIVEN THAT ALL EXISTING SERVICES ARE SHOWN.

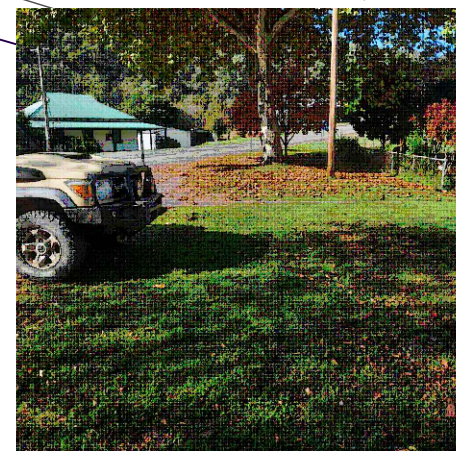

EXISTING CAR PARK GRASS AREA



**FINISHED DRAWING**  
 FOR DISCUSSION PURPOSES ONLY  
 SUBJECT TO FURTHER AMENDMENT  
 SIGNED RACHAEL GADD  
 DATE 26-MARCH-2023

REV	DATE	COMMENT	INITIALS
REVA	23/05/22	TENDER ISSUE	CM
REVB	26/03/23	CONSTRUCTION ISSUE	CM

**towongshire**  
 Innovation : technology : sustainability  
 32 TOWONG STREET [PO BOX 55]  
 TALLANGATTA VIC 3700  
 02 6071 5100  
 WWW.TOWONG.VIC.GOV.AU

**TOWONG SHIRE COUNCIL**  
 OMEO\_HIGHWAY  
 MITTA\_MITTA VIC 3701  
 MITTA\_MITTA\_PATHWAYS\_AND\_INFRASTRUCTURE  
 PLAN\_SHEET\_3\_OF\_6

DESIGNED	CM	DRAWING NO	
DRAWN	CM	T210809	
CHECKED	RG		
APPROVED	RG	SHEET NO	PAGE SIZE
	SCALE 1:250 UNIT METRES	7	A3



**WARNING**  
 BEWARE OF UNDERGROUND SERVICES  
 THE LOCATIONS OF UNDERGROUND SERVICES ARE APPROXIMATE ONLY AND THEIR EXACT POSITION SHOULD BE PROVEN ON SITE. NO GUARANTEE IS GIVEN THAT ALL EXISTING SERVICES ARE SHOWN.

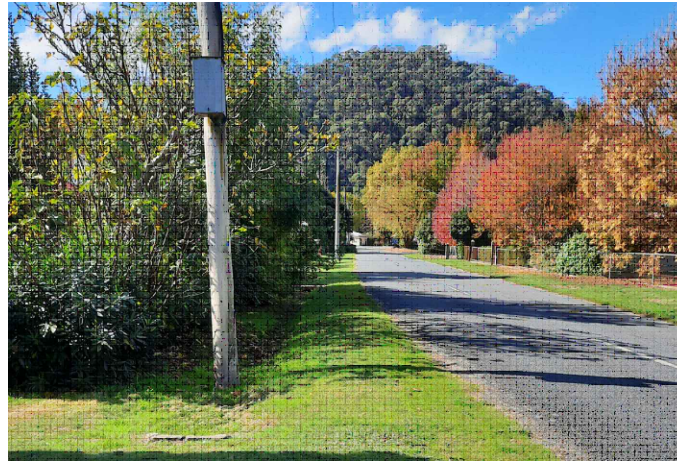

SHAPE TURFED SWALE DRAIN ALONGSIDE PATHWAY REFER IDM SD500 & SHEET 18

CAUTION: PRIVATE UNDERGROUND WATER SUPPLY PIPES IN VICINITY OF WORKS  
 HNo12

1.5m WIDE CONCRETE PATHWAY REFER SD205

REMOVE EXISTING BOUNDARY TREE LINE. REPLACE AS REQUIRED BY PROPERTY OWNER

CH 140.0

HNo5554

CH 160.0

CH 180.0

CH 200.0

CH 220.0

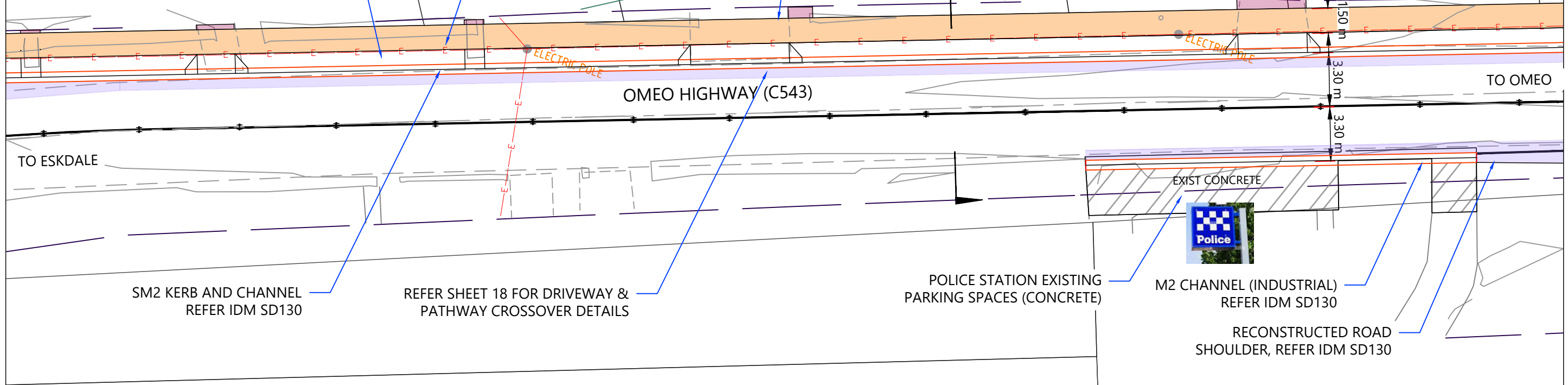

**FINISHED DRAWING**  
 FOR DISCUSSION PURPOSES ONLY  
 SUBJECT TO FURTHER AMENDMENT  
 SIGNED RACHAEL GADD  
 DATE 26-MARCH-2023

REV	DATE	COMMENT	INITIALS
REVA	23/05/22	TENDER ISSUE	CM
REVB	26/03/23	CONSTRUCTION ISSUE	CM

**towongshire**  
 Innovation : technology : sustainability  
 32 TOWONG STREET [PO BOX 55]  
 TALLANGATTA VIC 3700  
 02 6071 5100  
 WWW.TOWONG.VIC.GOV.AU

**TOWONG SHIRE COUNCIL**  
 OMEO\_HIGHWAY  
 MITTA\_MITTA VIC 3701  
 MITTA\_MITTA\_PATHWAYS\_AND\_INFRASTRUCTURE  
 PLAN\_SHEET\_4\_OF\_6

DESIGNED	CM	DRAWING NO	
DRAWN	CM	T210809	
CHECKED	RG	SHEET NO	PAGE SIZE
APPROVED	RG	8	A3
SCALE	1:250		
UNIT	METRES		



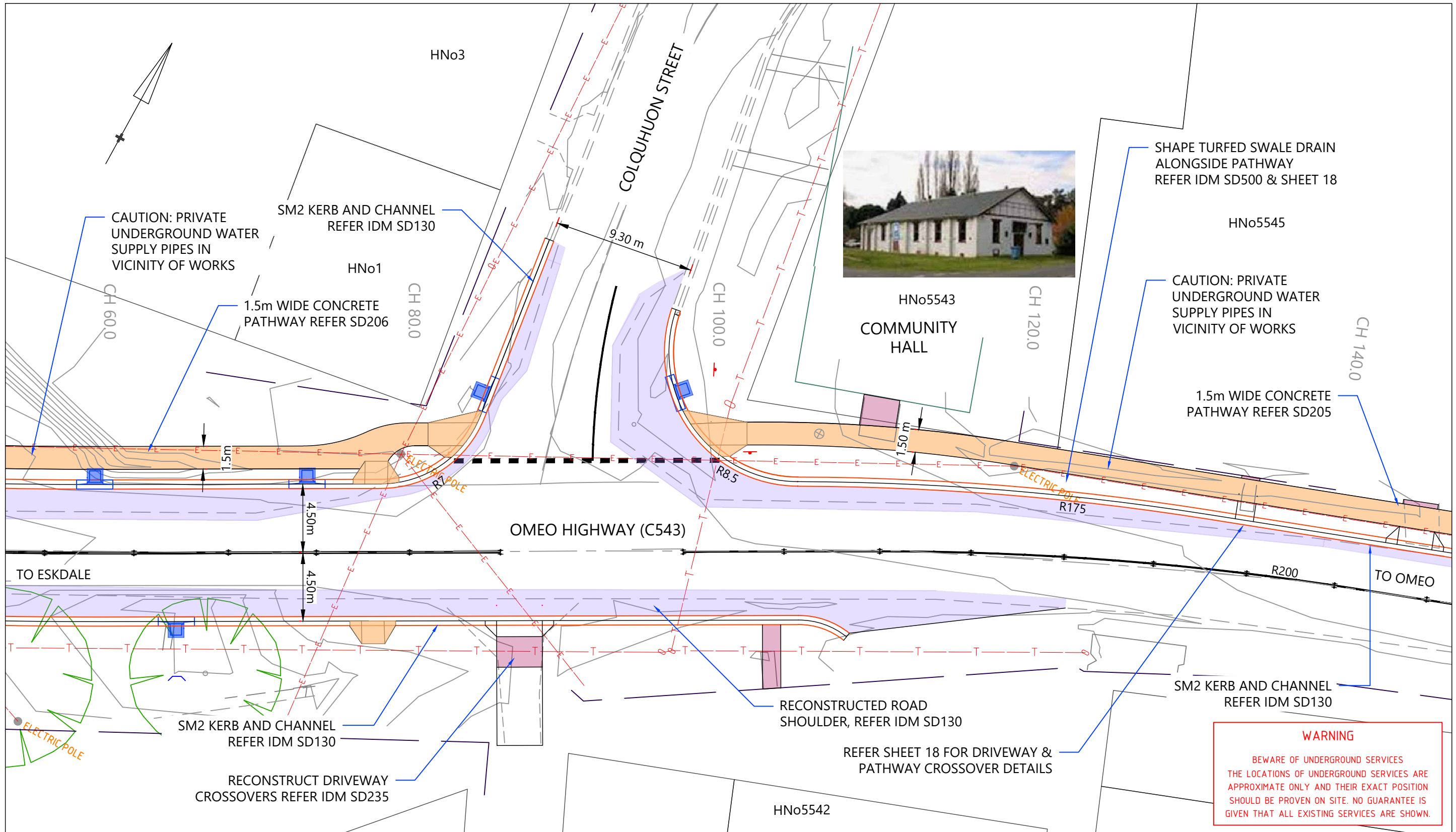

SHAPE TURFED SWALE DRAIN  
ALONGSIDE PATHWAY  
REFER IDM SD500 & SHEET 18

CAUTION: PRIVATE  
UNDERGROUND WATER  
SUPPLY PIPES IN  
VICINITY OF WORKS

CAUTION: PRIVATE  
UNDERGROUND WATER  
SUPPLY PIPES IN  
VICINITY OF WORKS

1.5m WIDE CONCRETE  
PATHWAY REFER SD205

SM2 KERB AND CHANNEL  
REFER IDM SD130

RECONSTRUCTED ROAD  
SHOULDER, REFER IDM SD130

SM2 KERB AND CHANNEL  
REFER IDM SD130

RECONSTRUCT DRIVEWAY  
CROSSOVERS REFER IDM SD235

REFER SHEET 18 FOR DRIVEWAY &  
PATHWAY CROSSOVER DETAILS

**WARNING**  
BEWARE OF UNDERGROUND SERVICES  
THE LOCATIONS OF UNDERGROUND SERVICES ARE  
APPROXIMATE ONLY AND THEIR EXACT POSITION  
SHOULD BE PROVEN ON SITE. NO GUARANTEE IS  
GIVEN THAT ALL EXISTING SERVICES ARE SHOWN.



DYBD REQUIRED BEFORE ALL WORKS COMMENCE

**FINISHED DRAWING**  
FOR DISCUSSION PURPOSES ONLY  
SUBJECT TO FURTHER AMENDMENT  
SIGNED RACHAEL GADD  
DATE 26-MARCH-2023

REV	DATE	COMMENT	INITIALS
REVA	23/05/22	TENDER ISSUE	CM
REVB	26/03/23	CONSTRUCTION ISSUE	CM

**towongshire**  
Innovation : technology : sustainability  
32 TOWONG STREET [PO BOX 55]  
TALLANGATTA VIC 3700  
02 6071 5100  
WWW.TOWONG.VIC.GOV.AU

**TOWONG SHIRE COUNCIL**  
OMEO\_HIGHWAY  
MITTA\_MITTA VIC 3701  
MITTA\_MITTA\_PATHWAYS\_AND\_INFRASTRUCTURE  
PLAN\_SHEET\_5\_OF\_6

DESIGNED	CM	DRAWING NO	
DRAWN	CM	T210809	
CHECKED	RG	SHEET NO	PAGE SIZE
APPROVED	RG	9	A3
SCALE	1:250		
UNIT	METRES		



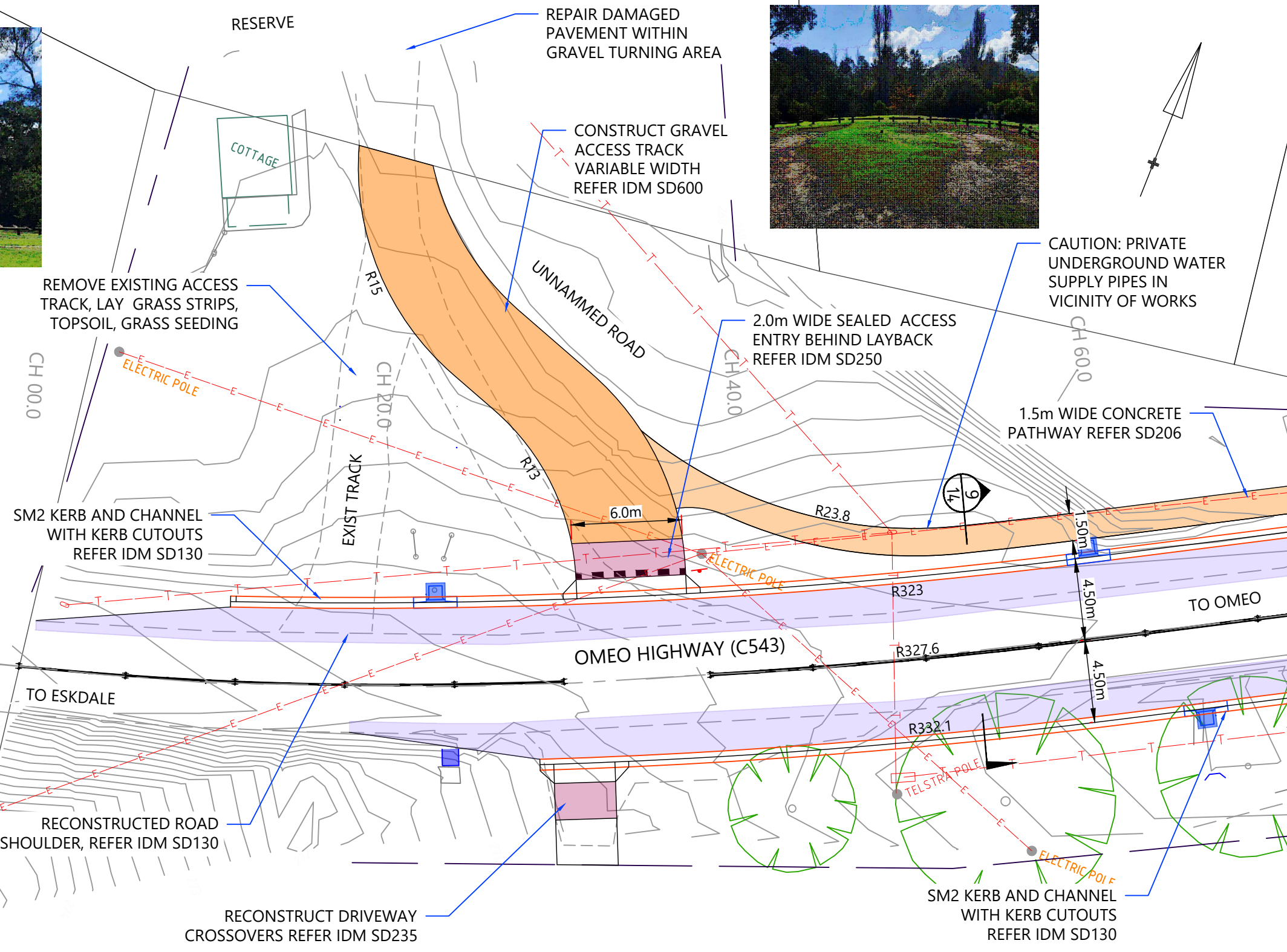
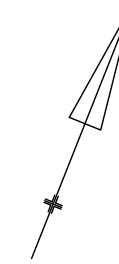

**WARNING**  
 BEWARE OF UNDERGROUND SERVICES  
 THE LOCATIONS OF UNDERGROUND SERVICES ARE APPROXIMATE ONLY AND THEIR EXACT POSITION SHOULD BE PROVEN ON SITE. NO GUARANTEE IS GIVEN THAT ALL EXISTING SERVICES ARE SHOWN.

DIAL BEFORE YOU DIG  
www.1100.com.au

DYBD REQUIRED BEFORE ALL WORKS COMMENCE

**FINISHED DRAWING**  
 FOR DISCUSSION PURPOSES ONLY  
 SUBJECT TO FURTHER AMENDMENT  
 SIGNED RACHAEL GADD  
 DATE 26-MARCH-2023

REV	DATE	COMMENT	INITIALS
REVA	23/05/22	TENDER ISSUE	CM
REVB	26/03/23	CONSTRUCTION ISSUE	CM

32 TOWONG STREET [PO BOX 55]  
 TALLANGATTA VIC 3700  
 02 6071 5100  
 WWW.TOWONG.VIC.GOV.AU

**TOWONG SHIRE COUNCIL**  
 OMEO\_HIGHWAY  
 MITTA\_MITTA VIC 3701  
 MITTA\_MITTA\_PATHWAYS\_AND\_INFRASTRUCTURE  
 PLAN\_SHEET\_6\_OF\_6

DESIGNED		CM	DRAWING NO	
DRAWN		CM	T210809	
CHECKED		RG		
APPROVED		RG	SHEET NO	PAGE SIZE
SCALE		1:250	10	A3
UNIT		METRES		



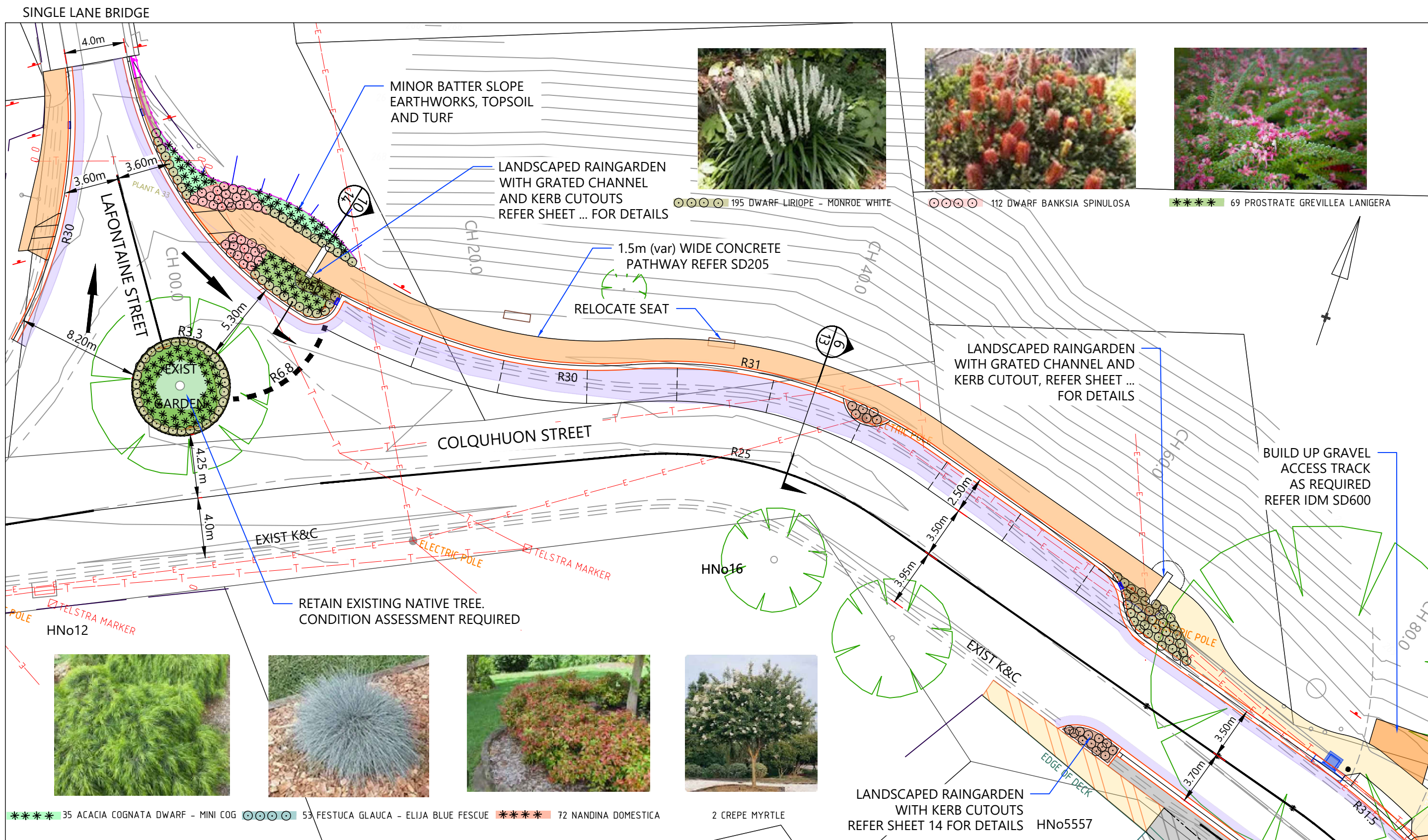

195 DWARF LIRIOPE - MONROE WHITE



112 DWARF BANKSIA SPINULOSA



69 PROSTRATE GREVILLEA LANIGERA



35 ACACIA COGNATA DWARF - MINI COG



53 FESTUCA GLAUCA - ELIZA BLUE FESCUE



72 NANDINA DOMESTICA



2 CREPE MYRTLE

**FINISHED DRAWING**  
 FOR DISCUSSION PURPOSES ONLY  
 SUBJECT TO FURTHER AMENDMENT  
 SIGNED RACHAEL GADD  
 DATE 26-MARCH-2023

REV	DATE	COMMENT	INITIALS
REVA	23/05/22	TENDER ISSUE	CM
REVB	26/03/23	CONSTRUCTION ISSUE	CM

**TOWONG SHIRE COUNCIL**  
 OMEO\_HIGHWAY  
 MITTA\_MITTA VIC 3701  
 MITTA\_MITTA\_PATHWAYS\_AND\_INFRASTRUCTURE  
 LANDSCAPE\_PLAN\_SHEET\_1\_OF\_2

DESIGNED	CM	DRAWING NO	
DRAWN	CM	T210809	
CHECKED	RG	SHEET NO	PAGE SIZE
APPROVED	RG	11	A3
SCALE	1:250		
UNIT	METRES		



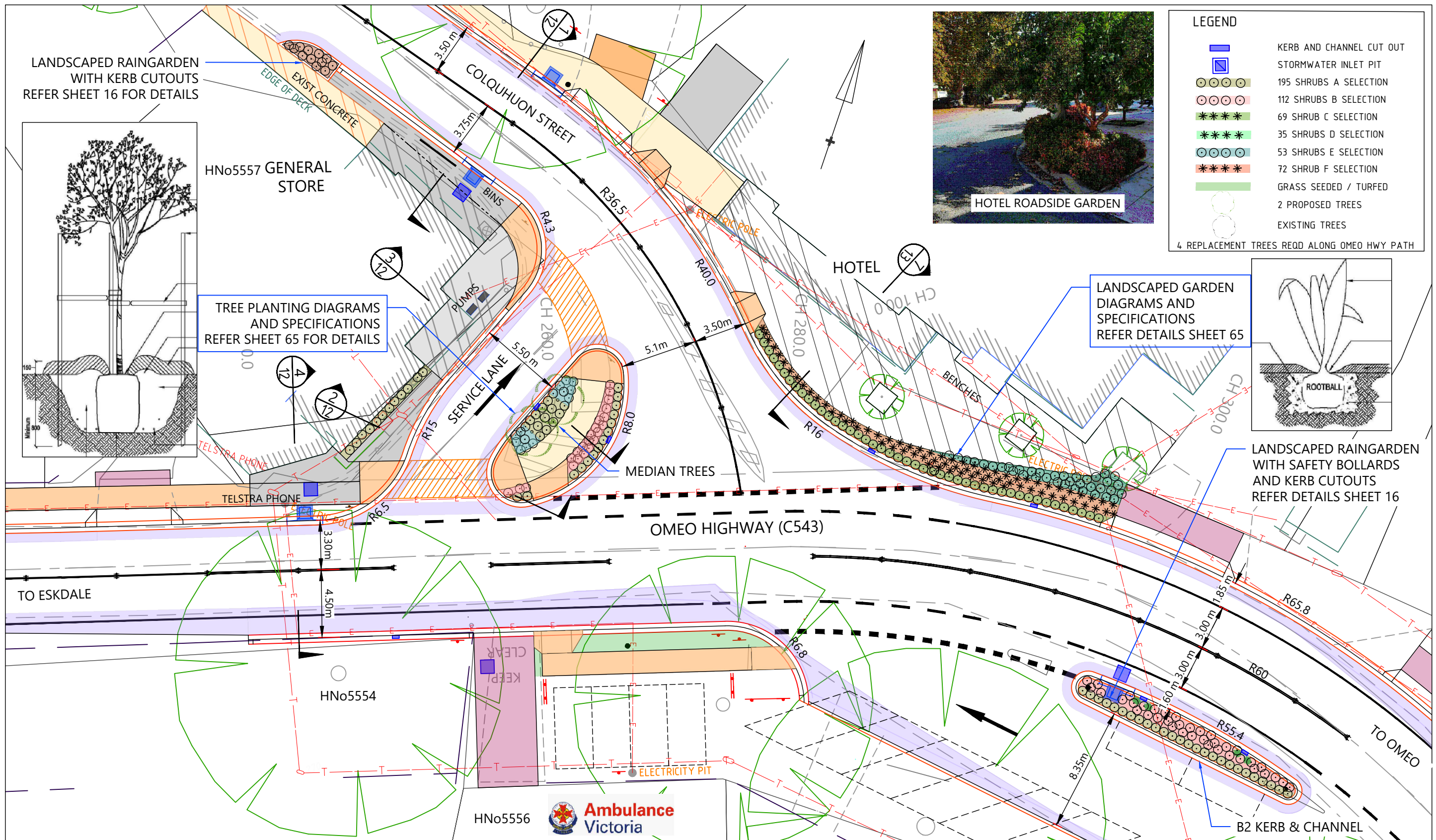

**FINISHED DRAWING**  
 FOR DISCUSSION PURPOSES ONLY  
 SUBJECT TO FURTHER AMENDMENT  
 SIGNED RACHAEL GADD  
 DATE 26-MARCH-2023

REV	DATE	COMMENT	INITIALS
REVA	23/05/22	TENDER ISSUE	CM
REVB	26/03/23	CONSTRUCTION ISSUE	CM

**towongshire**  
 Innovation : technology : sustainability  
 32 TOWONG STREET [PO BOX 55]  
 TALLANGATTA VIC 3700  
 02 6071 5100  
 WWW.TOWONG.VIC.GOV.AU

**TOWONG SHIRE COUNCIL**  
 OMEO\_HIGHWAY  
 MITTA\_MITTA VIC 3701  
 MITTA\_MITTA\_PATHWAYS\_AND\_INFRASTRUCTURE  
 LANDSCAPE\_PLAN\_SHEET\_2\_OF\_2

DESIGNED	CM	DRAWING NO	
DRAWN	CM	T210809	
CHECKED	RG	SHEET NO	PAGE SIZE
APPROVED	RG	12	A3
SCALE	1:250		
UNIT	METRES		



**PAVEMENT TYPE A: PAVEMENT REINSTATEMENT**

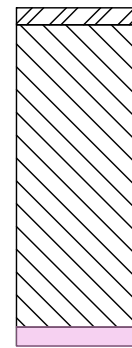

10 mm C170/10 SINGLE COAT SPRAY SEAL  
  
MIN. 250 mm CLASS 2 FINE CRUSHED ROCK 99% MMDD  
2% OMC OR APPROVED EQUIVALENT  
OR TO MATCH EXISTING PAVEMENT

(REFER TO PAVEMENT FOR LOCATION)

**PAVEMENT TYPE B : CONCRETE FOOTPATH**

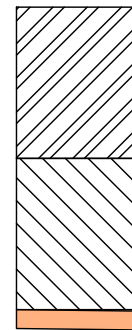

125 mm (25 MPa) CONCRETE WITH SL72 SLAB  
REINFORCEMENT CENTRALLY PLACED AS PER IDM SD 205  
  
100 mm THICK LAYER OF CLASS 3 FCR BEDDING  
COMPACTED TO 97% MMDD OR APPROVED EQUIVALENT

(REFER TO PAVEMENT FOR LOCATION)

**PAVEMENT TYPE E: SEAL REINSTATEMENT**

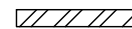

10 mm C170/10 SINGLE COAT SPRAY SEAL  
MIN. 300 mm SEAL OVERLAP OVER PAST EXISTING  
PAVEMENT

(REFER TO PAVEMENT FOR LOCATION)

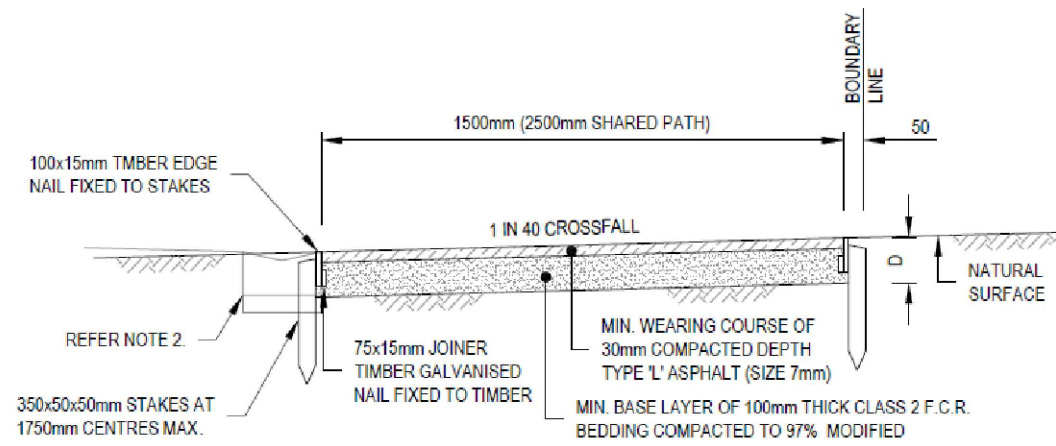

**TYPICAL 130mm ASPHALT PATH WITH TIMBER EDGE SECTION**

REFER IDM SD206 TYPICAL HOTMIX ASPHALT FOOTPATH

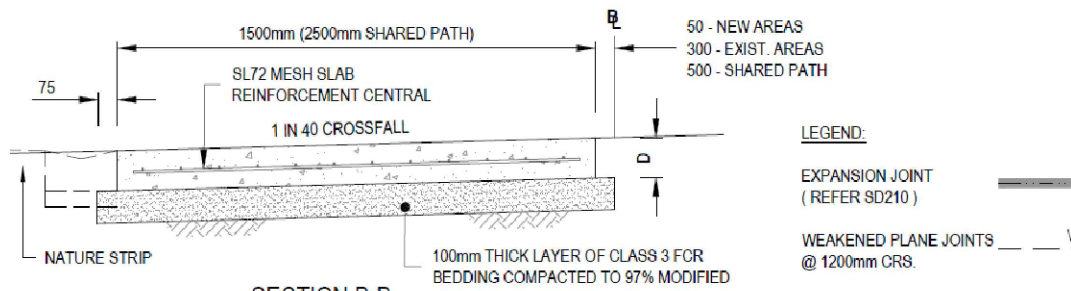

**SECTION B-B  
TYPICAL 125mm & 150mm FOOTPATH SECTION**

REFER IDM SD205 TYPICAL FOOTPATH DETAIL

**PAVEMENT TYPE C: ASPHALT FOOTPATH**

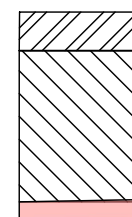

30 mm TYPE L ASPHALT SIZE 7mm  
  
MIN. 100 mm CLASS 2 FINE CRUSHED ROCK  
97% MMDD

(REFER TO PAVEMENT FOR LOCATION)

**PAVEMENT TYPE D: DRIVEWAY (MATCH TO EXISTING)**

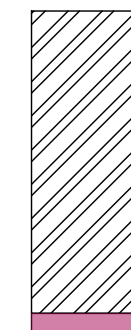

MATCH TO EXISTING DRIVEWAY PAVEMENT  
COMPOSITION, COMPOSITION VARIES & UNKNOWN  
(FOR CONCRETE DRIVEWAY CONSTRUCT AS PER IDM  
SD205)

(REFER TO PAVEMENT FOR LOCATION)

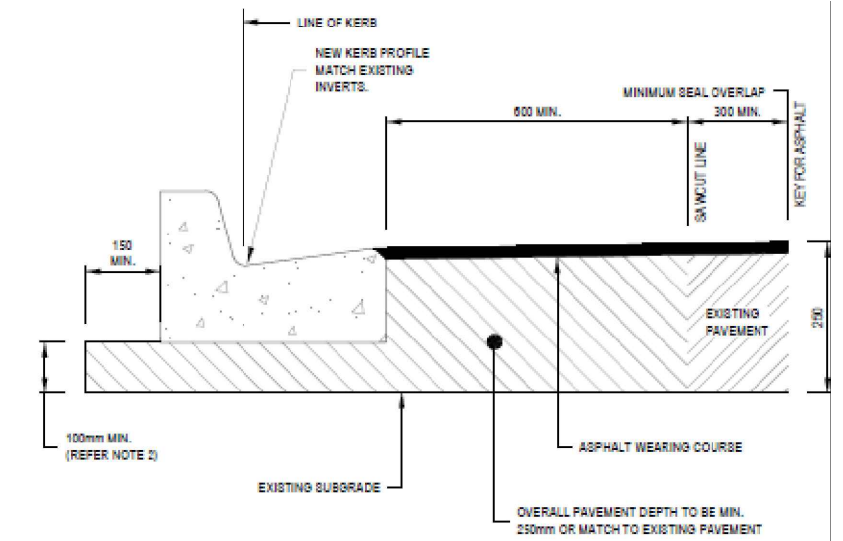

**TYPICAL SECTION**

**NOTES:**

- REFER TO CONCRETE AS. 2875-2000 CONCRETE KERBS AND CHANNELS FOR SPECIFIC REQUIREMENTS.
- 100mm MINIMUM COMPACTED DEPTH OF CLASS 3, 20mm F.C.R. BEDDING TO 97% MMDD OR EXTENSION OF ROAD PAVEMENT LAYERS, WHICH EVER IS GREATER, UNLESS OTHERWISE DIRECTED.
- WEARING COURSE ASPHALT TO BE MINIMUM 30mm COMPACTED DEPTH OF TYPE N, 10mm NOMINAL SIZE (U.N.O.)
- CONSTRUCTION JOINTS LOCATED - 2500mm MAXIMUM SPACING - 75mm MINIMUM DEPTH
- WIDTHS SPECIFIED IN CROSS SECTIONS ARE FACE (LINE) OF KERB.
- CONCRETE SHALL BE NORMAL CLASS N25 STANDARD STRENGTH GRADE COMPLYING WITH THE REQUIREMENTS OF AS. 1379. REFER TO VICROADS STANDARD SPECIFICATION T03 FOR REQUIREMENTS OF CONCRETE TO BE USED IN EXTRUSION MACHINES.
- CONCRETE TO BE SMOOTH TROWELLED FINISHED ON TRAY AND KERB.

REFER IDM 130 ABUTTING EXISTING PAVEMENT



**FINISHED DRAWING**  
FOR DISCUSSION PURPOSES ONLY  
SUBJECT TO FURTHER AMENDMENT  
SIGNED RACHAEL GADD  
DATE 26-MARCH-2023

REV	DATE	COMMENT	INITIALS
REVA	23/05/22	TENDER ISSUE	CM
REVB	26/03/23	CONSTRUCTION ISSUE	CM

**towongshire**  
Innovation : technology : sustainability  
32 TOWONG STREET [PO BOX 55]  
TALLANGATTA VIC 3700  
02 6071 5100  
WWW.TOWONG.VIC.GOV.AU

**TOWONG SHIRE COUNCIL**  
OME0\_HIGHWAY  
MITTA\_MITTA VIC 3701  
MITTA\_MITTA\_PATHWAYS\_AND\_INFRASTRUCTURE  
PAVEMENT\_DETAILS

DESIGNED	CM	DRAWING NO	
DRAWN	CM	T210809	
CHECKED	RG	SHEET NO	PAGE SIZE
APPROVED	RG	13	A3
SCALE	NTS		
UNIT	METRES		



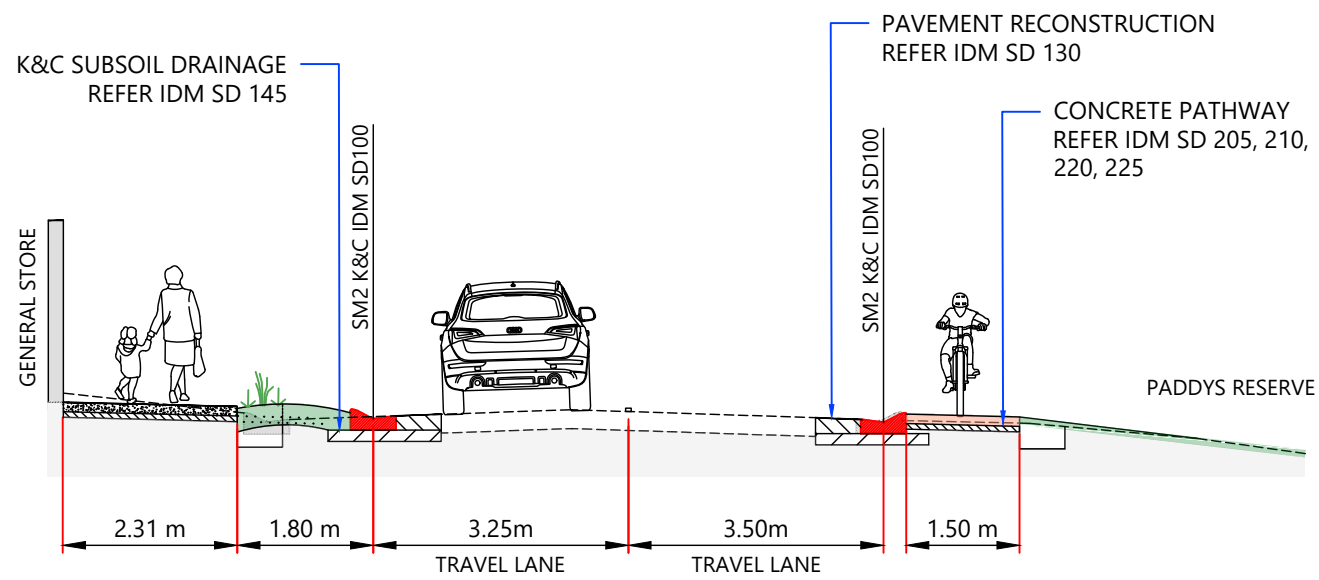

**COLQUHUON STREET - TYPICAL SECTION** (1/6)

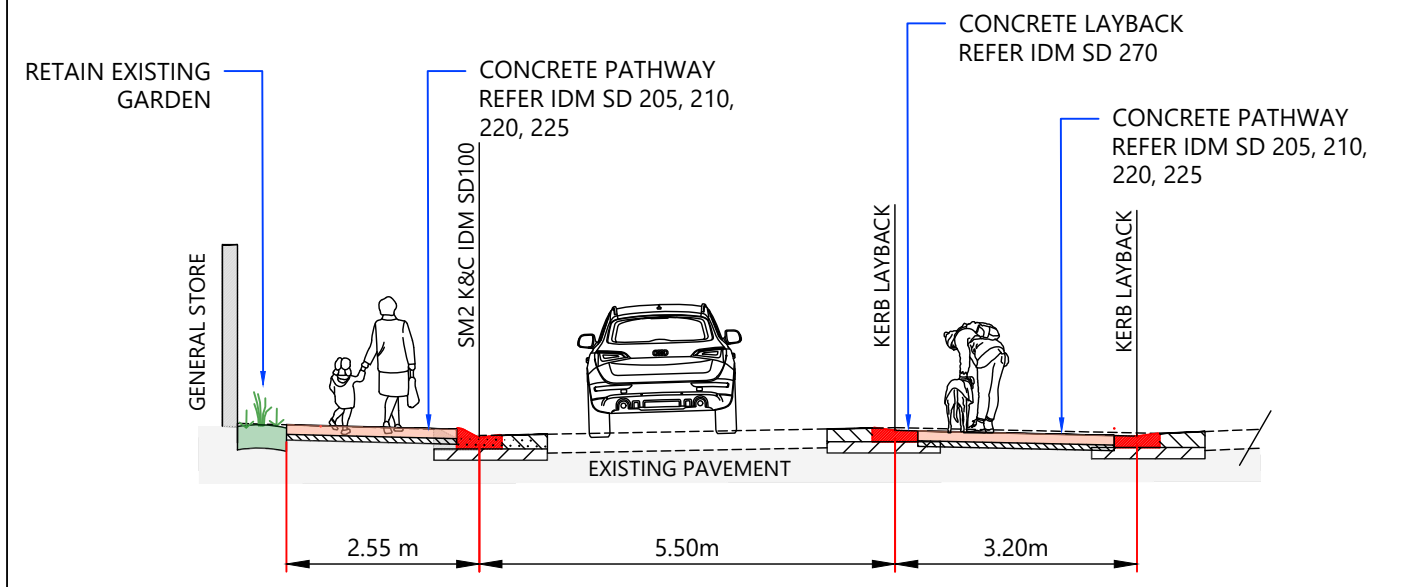

**SERVICE LANE - TYPICAL SECTION** (2/6)

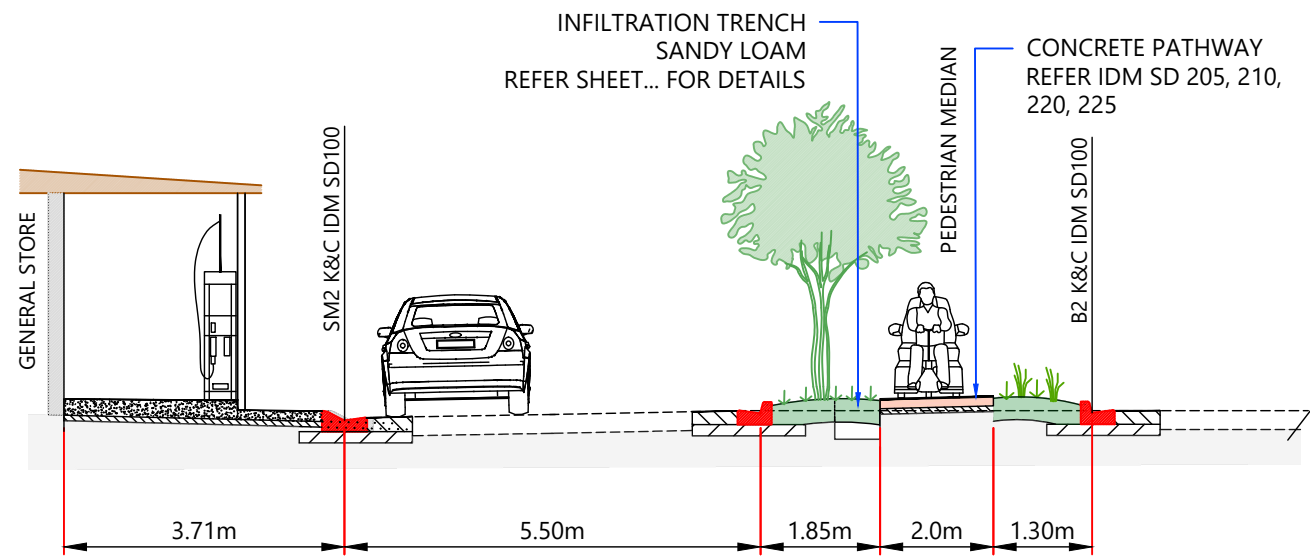

**SERVICE LANE - TYPICAL SECTION** (3/6)

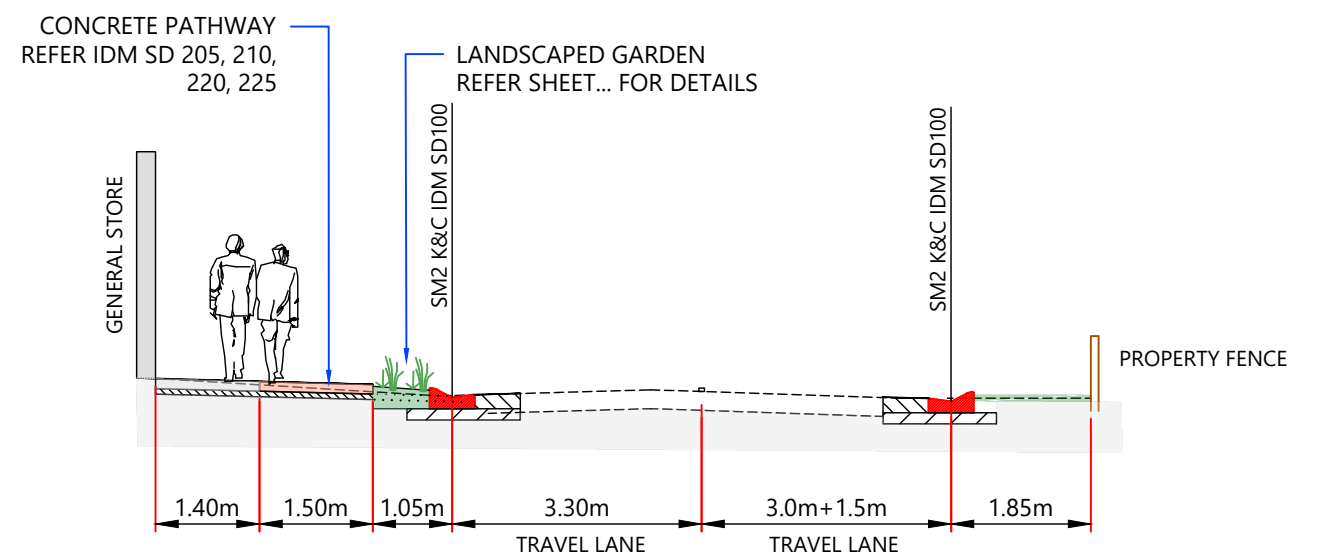

**OMEO HIGHWAY - TYPICAL SECTION** (4/6)



**FINISHED DRAWING**  
 FOR DISCUSSION PURPOSES ONLY  
 SUBJECT TO FURTHER AMENDMENT  
 SIGNED RACHAEL GADD  
 DATE 26-MARCH-2023

REV	DATE	COMMENT	INITIALS
REVA	23/05/22	TENDER ISSUE	CM
REVB	26/03/23	CONSTRUCTION ISSUE	CM

**towongshire**  
 Innovation : technology : sustainability  
 32 TOWONG STREET [PO BOX 55]  
 TALLANGATTA VIC 3700  
 02 6071 5100  
 WWW.TOWONG.VIC.GOV.AU

**TOWONG SHIRE COUNCIL**  
 OMEO\_HIGHWAY  
 MITTA\_MITTA VIC 3701  
 MITTA\_MITTA\_PATHWAYS\_AND\_INFRASTRUCTURE  
 TYPICAL\_SECTIONS\_SHEET\_1\_OF\_2

DESIGNED	CM	DRAWING NO	
DRAWN	CM	T210809	
CHECKED	RG	SHEET NO	PAGE SIZE
APPROVED	RG	14	A3
SCALE	1:250		
UNIT	METRES		



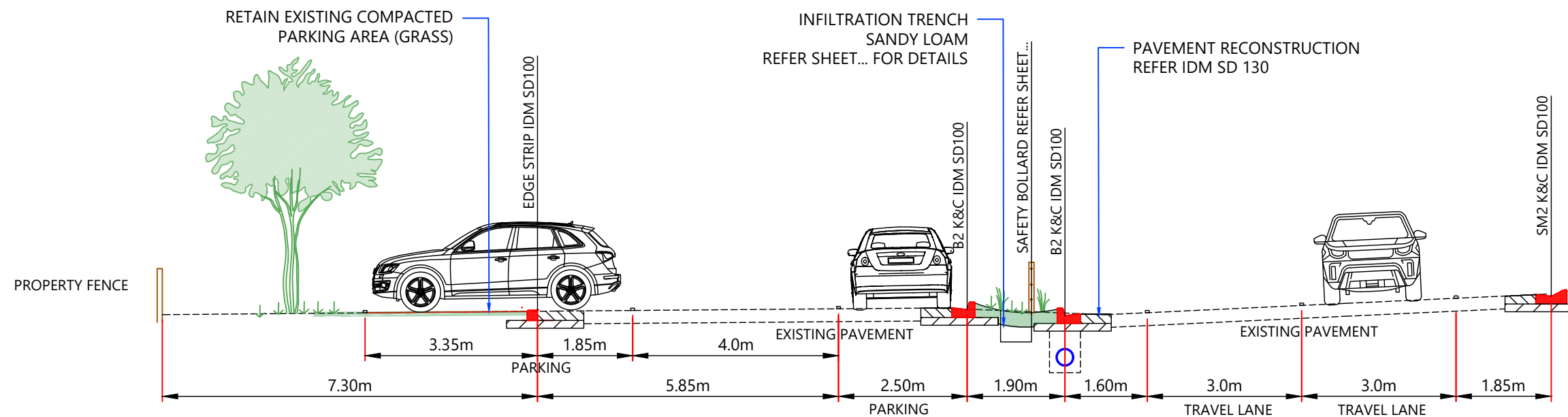

**CAR PARK / OMEO HIGHWAY - TYPICAL SECTION** (5/7)

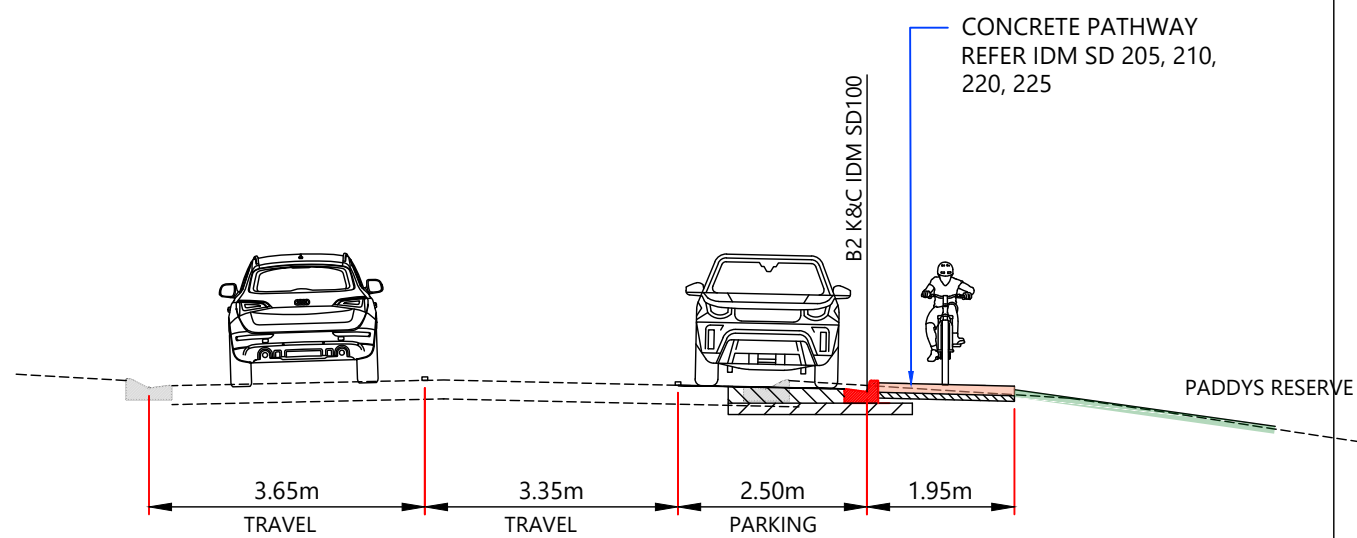

**COLQUHUON STREET - TYPICAL SECTION** (6/5)

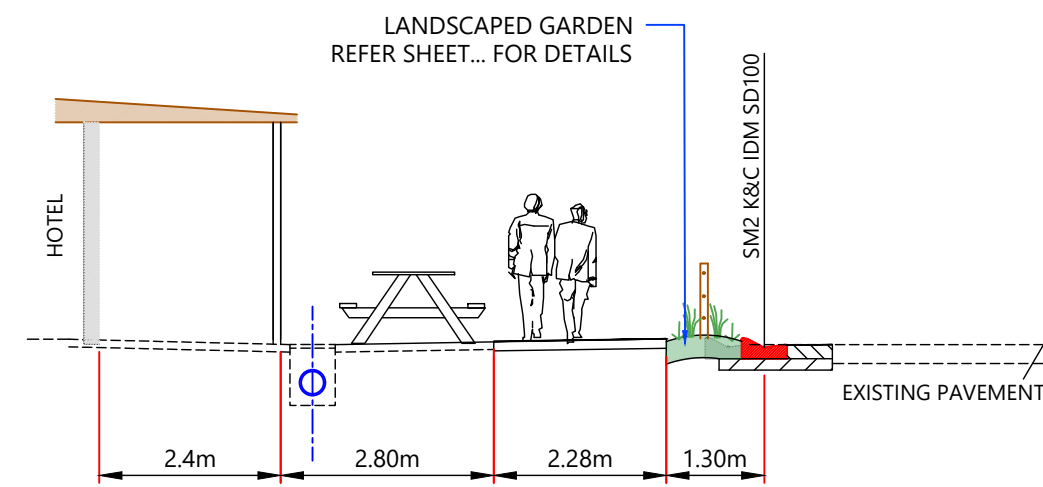

**COLQUHUON STREET - TYPICAL SECTION** (7/6)



DYBD REQUIRED BEFORE ALL WORKS COMMENCE

**FINISHED DRAWING**  
 FOR DISCUSSION PURPOSES ONLY  
 SUBJECT TO FURTHER AMENDMENT  
 SIGNED RACHAEL GADD  
 DATE 26-MARCH-2023

REV	DATE	COMMENT	INITIALS
REVA	23/05/22	TENDER ISSUE	CM
REVB	26/03/23	CONSTRUCTION ISSUE	CM

**towongshire**  
 Innovation : technology : sustainability  
 32 TOWONG STREET [PO BOX 55]  
 TALLANGATTA VIC 3700  
 02 6071 5100  
 WWW.TOWONG.VIC.GOV.AU

**TOWONG SHIRE COUNCIL**  
 OMEO\_HIGHWAY  
 MITTA\_MITTA VIC 3701  
 MITTA\_MITTA\_PATHWAYS\_AND\_INFRASTRUCTURE  
 TYPICAL\_SECTIONS\_SHEET\_2\_OF\_5

DESIGNED	CM	DRAWING NO	
DRAWN	CM	T210809	
CHECKED	RG	SHEET NO	PAGE SIZE
APPROVED	RG	15	A3
SCALE	1:250		
UNIT	METRES		



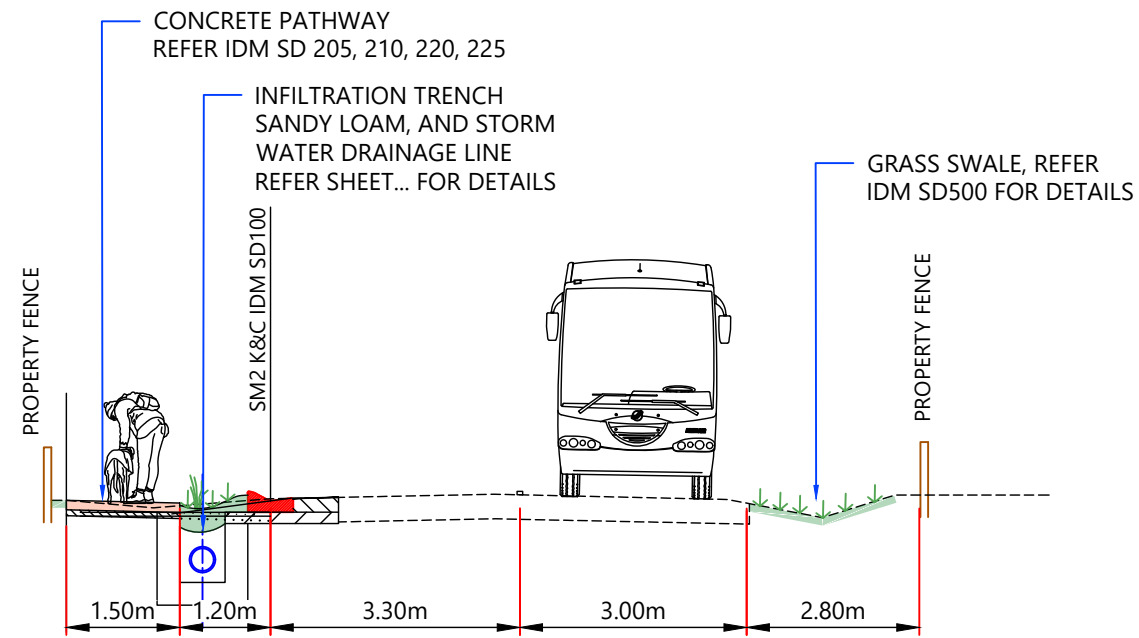

**OME0 HIGHWAY - TYPICAL SECTION** (8/8)

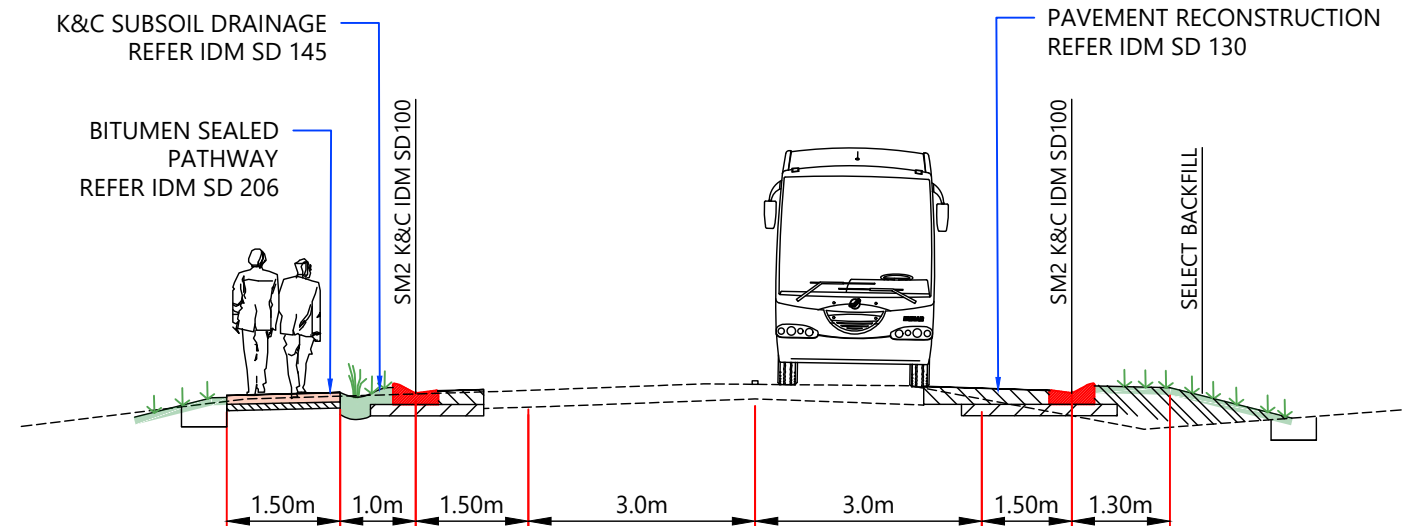

**OME0 HIGHWAY - TYPICAL SECTION** (9/10)

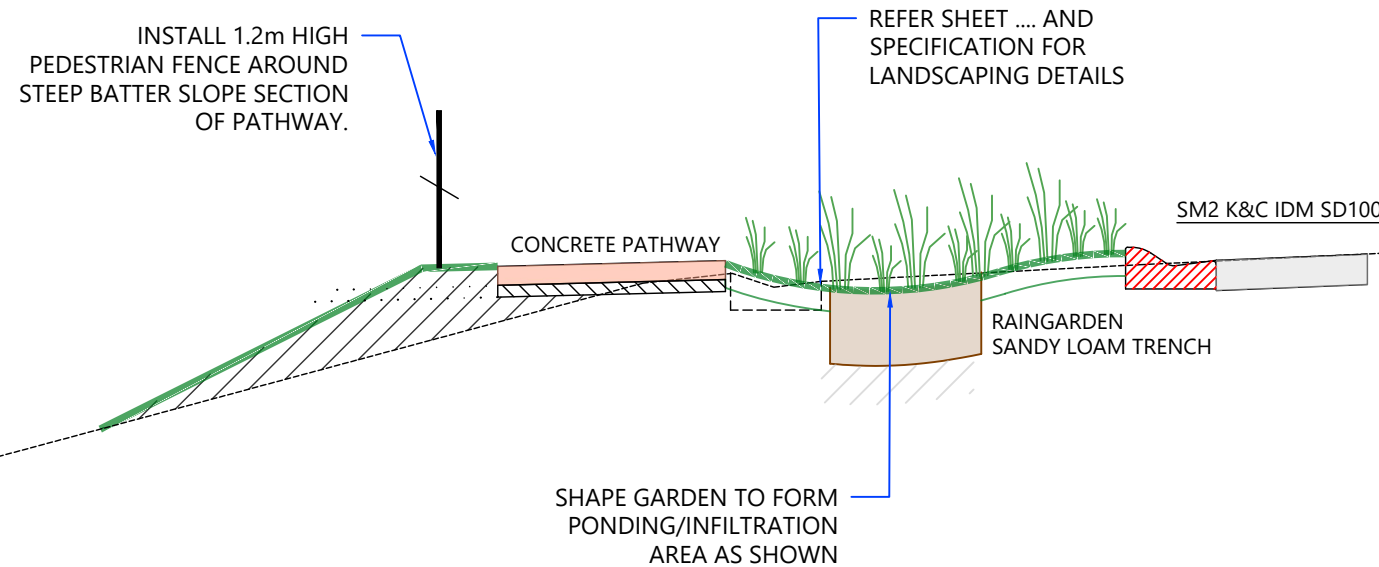

**COLQUHUON STREET - TYPICAL SECTIONS** (10/5)

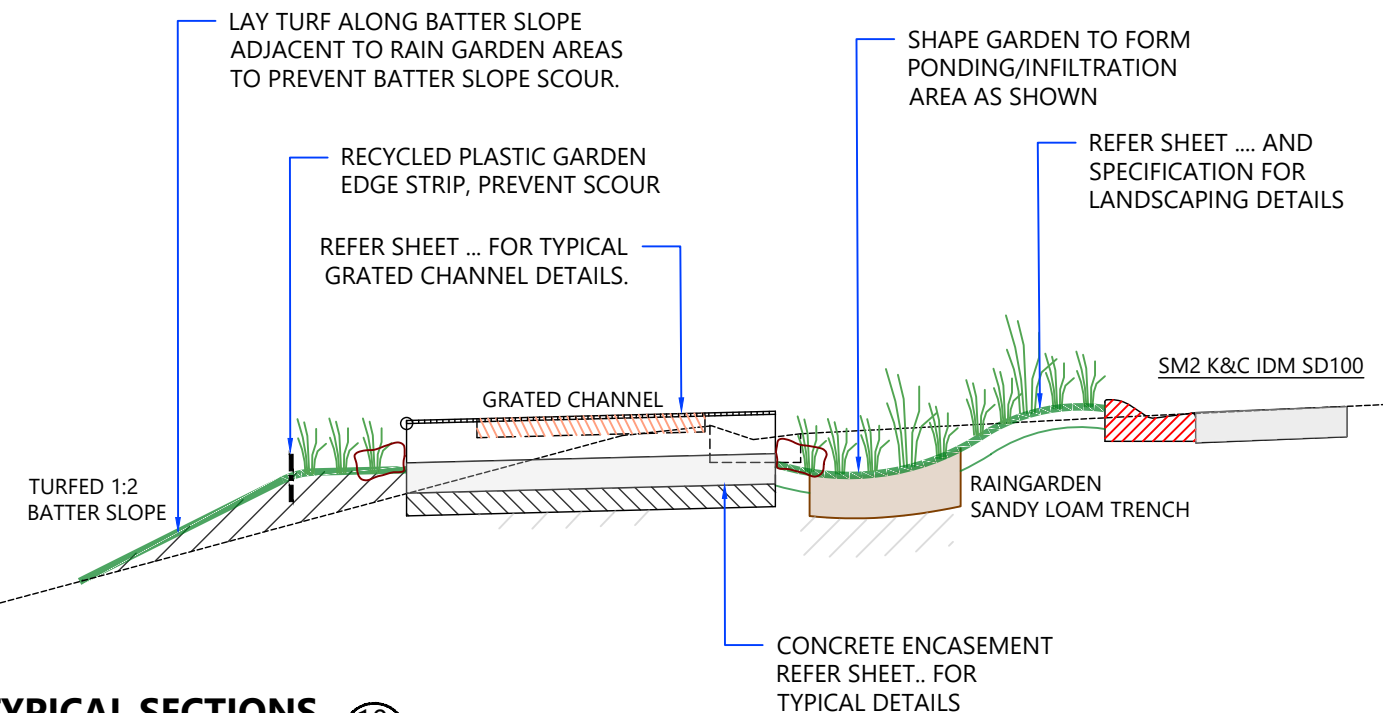

**FINISHED DRAWING**  
 FOR DISCUSSION PURPOSES ONLY  
 SUBJECT TO FURTHER AMENDMENT  
 SIGNED RACHAEL GADD  
 DATE 26-MARCH-2023

REV	DATE	COMMENT	INITIALS
REVA	23/05/22	TENDER ISSUE	CM
REVB	26/03/23	CONSTRUCTION ISSUE	CM

**towongshire**  
 Innovation : technology : sustainability  
 32 TOWONG STREET [PO BOX 55]  
 TALLANGATTA VIC 3700  
 02 6071 5100  
 WWW.TOWONG.VIC.GOV.AU

**TOWONG SHIRE COUNCIL**  
 OME0\_HIGHWAY  
 MITTA\_MITTA VIC 3701  
 MITTA\_MITTA\_PATHWAYS\_AND\_INFRASTRUCTURE  
 TYPICAL\_SECTIONS\_SHEET\_3\_OF\_5

DESIGNED	CM	DRAWING NO	
DRAWN	CM	T210809	
CHECKED	RG	SHEET NO	PAGE SIZE
APPROVED	RG	16	A3
SCALE	1:250		
UNIT	METRES		



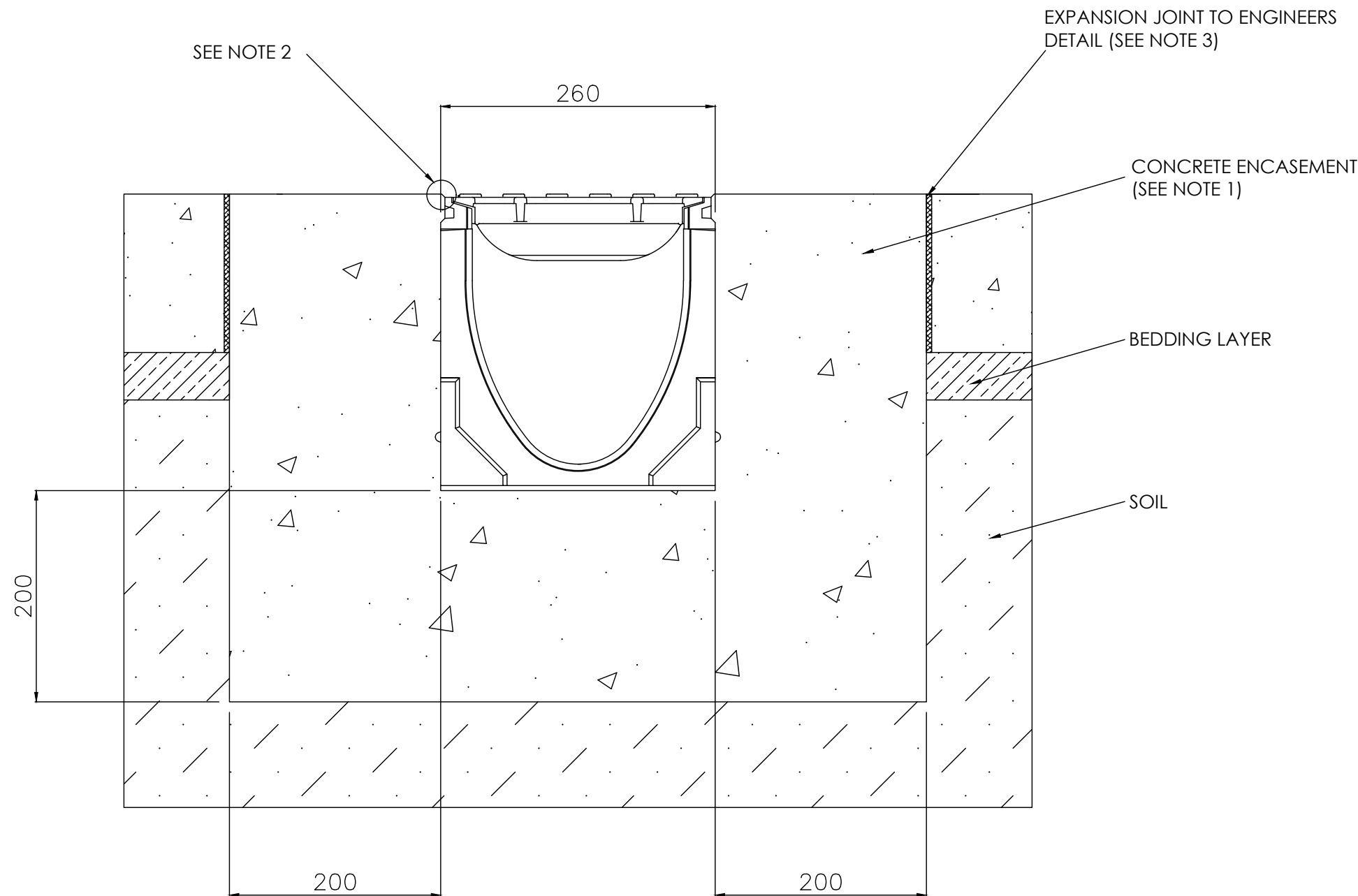

**SPECIFICATION CLAUSE  
POWERDRAIN S200K - LOAD CLASS E-G**

**GENERAL**

THE SURFACE DRAINAGE SYSTEM SHALL BE ACO'S POWERDRAIN S200K POLYMER CONCRETE V-PROFILE CHANNEL SYSTEM WITH DUCTILE IRON EDGE RAILS AS MANUFACTURED BY ACO.

**MATERIALS**

S200K CHANNELS SHALL BE MANUFACTURED FROM POLYESTER RESIN POLYMER CONCRETE WITH AN INTEGRALLY CAST-IN DUCTILE IRON EDGE RAIL. PROPERTIES OF POLYMER CONCRETE WILL BE AS FOLLOWS WITH SUPPORTING DOCUMENTATION:

COMPRESSIVE STRENGTH:	<b>98 MPa</b>
FLEXURAL STRENGTH:	<b>26 MPa</b>
TENSILE STRENGTH:	<b>14 MPa</b>
WATER ABSORPTION:	<b>0.07%</b>
FROST PROOF:	<b>YES</b>
COEFFICIENT OF EXPANSION/CONTRACTION:	<b>2.02x10<sup>-5</sup>/°C</b>
WATER VAPOUR TRANSMISSION:	<b>0.0364g/m<sup>2</sup></b>
NON FLAMMABLE:	<b>YES</b>
COEFFICIENT OF ROUGHNESS (MANNINGS):	<b>n=0.011</b>
RESISTANT TO WEATHERING:	<b>YES</b>
DILUTE ACID AND ALKALI RESISTANT:	<b>YES</b>
SF SEALANT GROOVE	<b>YES</b>

**CHANNELS**

S200K CHANNEL SHALL BE 200mm NOMINAL INTERNAL WIDTH WITH AN OVERALL WIDTH OF 260mm. CHANNEL INVERT SHALL HAVE A V-PROFILE TO ALLOW EFFICIENT DRAINAGE. S200K SLOPED CHANNELS SHALL HAVE A BUILT-IN SLOPE OF 0.5%. ALL CHANNELS SHALL BE INTERLOCKING WITH A MALE/FEMALE JOINT.

**GRATES**

INSERT SPECIFICATION FOR THE SELECTED GRATE. REFER TO THE RELEVANT ACO SPECIFICATION INFORMATION SHEET, CLICK [www.acodrain.com.au/resources](http://www.acodrain.com.au/resources).

**INSTALLATION**

THE COMPLETE DRAINAGE SYSTEM SHALL BE BY ACO AND TO BE INSTALLED FOR ITS INTENDED PURPOSE. ANY DEVIATION OR PARTIAL USE OF THE SPECIFIED SYSTEM AND/OR IMPROPER INSTALLATION WILL VOID ALL WARRANTIES PROVIDED BY ACO.

**NOTES:**

1. Specific site conditions may require an increase in the concrete encasement dimensions and/or reinforcement. It is the customer's responsibility to ensure the concrete encasement is designed for the application. A minimum concrete strength of 25MPa is recommended. The concrete should be vibrated to eliminate air pockets. Engineering advice may be required.
2. The finished level of the concrete encasement must be approximately 3mm above the top of the channel edge.
3. Expansion and crack control joints are recommended to protect the channel and the concrete encasement. Engineering advice may be required.
4. For further details, refer to ACO's design & site installation files at [www.acodrain.com.au/resources](http://www.acodrain.com.au/resources).

**TYPICAL GRATED CHANNEL DETAILS**



DYBD REQUIRED BEFORE ALL WORKS COMMENCE

**FINISHED DRAWING**

FOR DISCUSSION PURPOSES ONLY  
SUBJECT TO FURTHER AMENDMENT

SIGNED RACHAEL GADD  
DATE 26-MARCH-2023

REV	DATE	COMMENT	INITIALS
REVA	23/05/22	TENDER ISSUE	CM
REVB	26/03/23	CONSTRUCTION ISSUE	CM



32 TOWONG STREET [PO BOX 55]  
TALLANGATTA VIC 3700  
02 6071 5100  
WWW.TOWONG.VIC.GOV.AU

**TOWONG SHIRE COUNCIL**

OMEQ\_HIGHWAY  
MITTA\_MITTA VIC 3701  
MITTA\_MITTA\_PATHWAYS\_AND\_INFRASTRUCTURE

TYPICAL\_SECTIONS\_SHEET\_4\_OF\_5

DESIGNED	CM	DRAWING NO	
DRAWN	CM	T210809	
CHECKED	RG	SHEET NO	PAGE SIZE
APPROVED	RG	17	A3
SCALE	1:250		
UNIT	METRES		



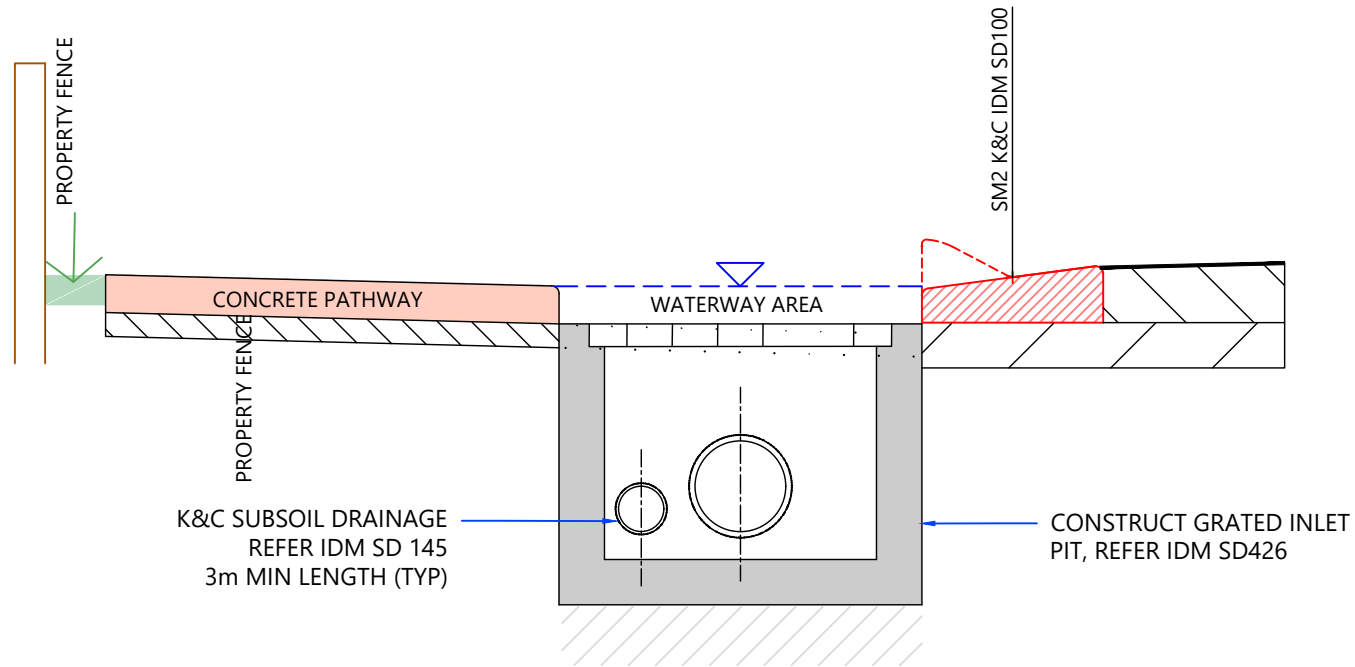

**OMEO HIGHWAY - TYPICAL PIT SECTION** 8  
8

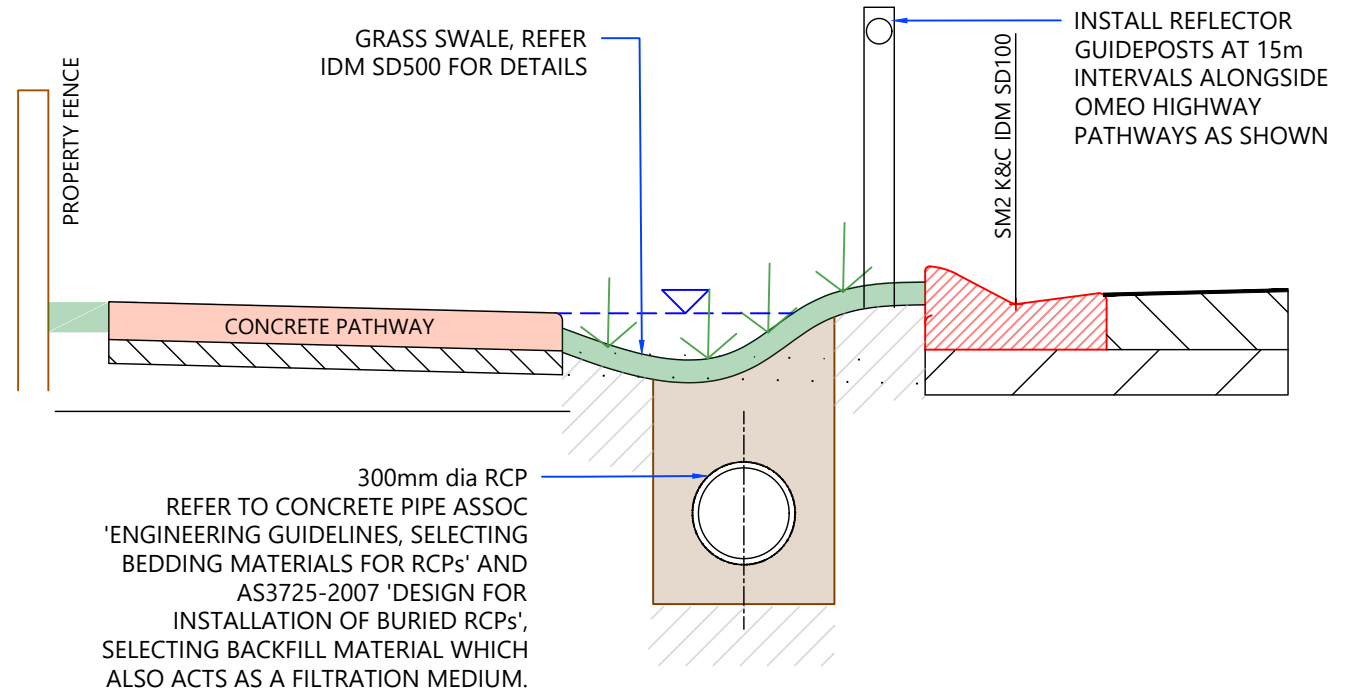

**OMEO HIGHWAY - TYPICAL SWALE SECTION** 9  
10

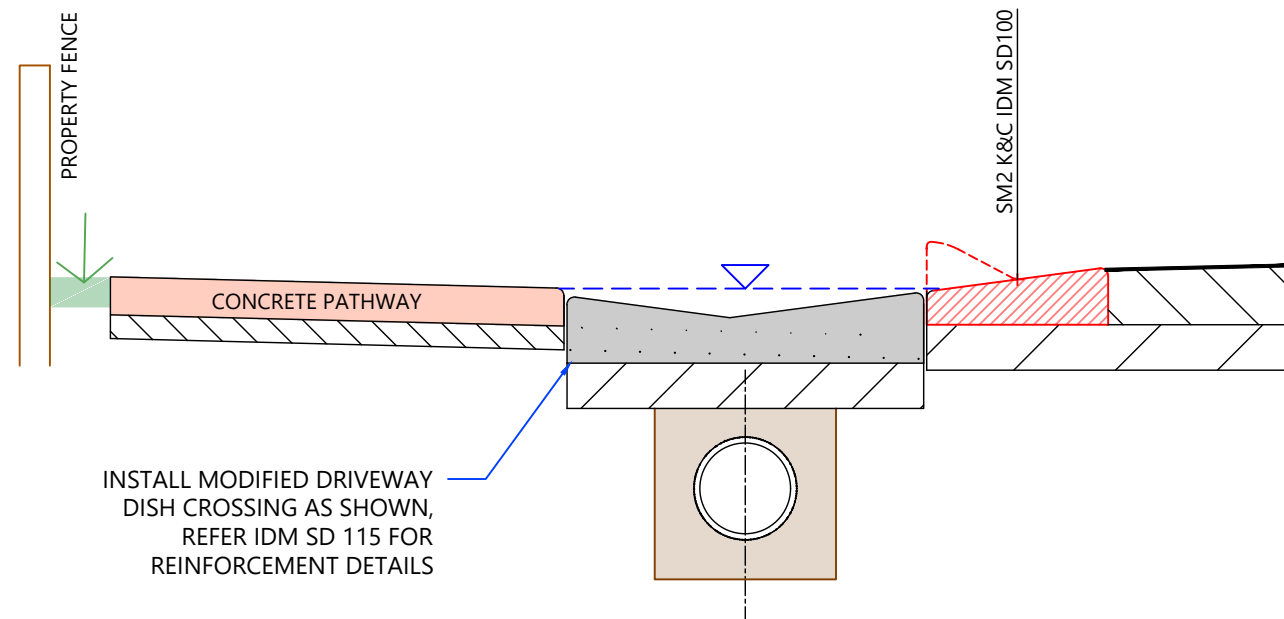

**OMEO HIGHWAY - TYPICAL DRIVEWAY SECTIONS** 8  
8

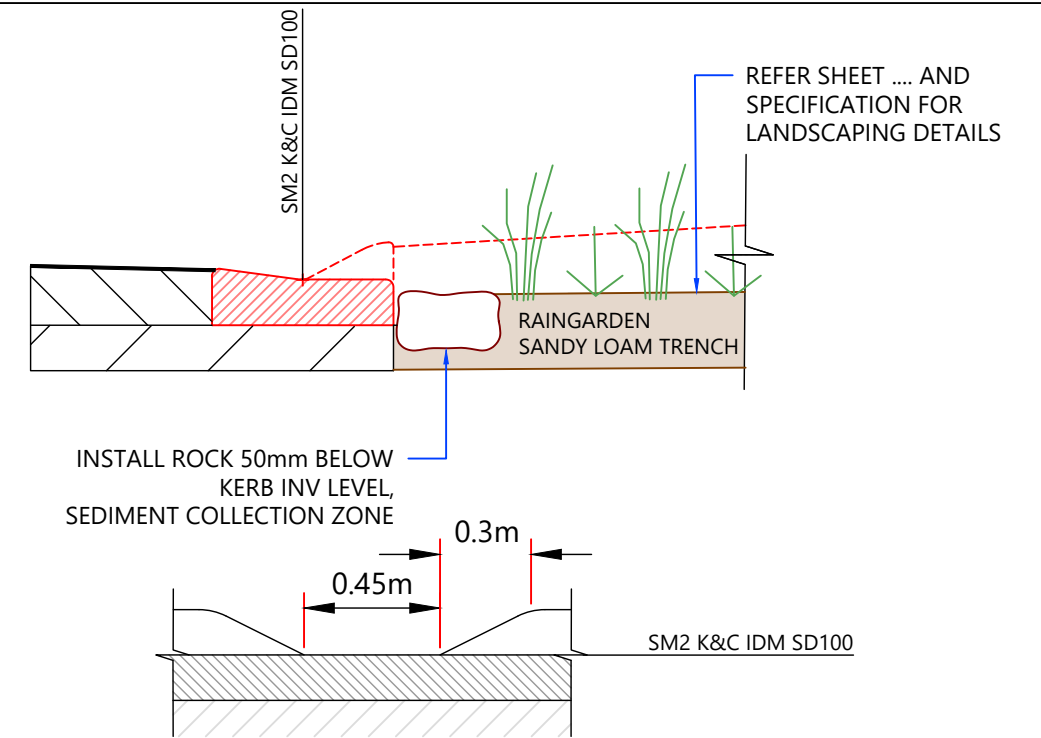

**COLQUHUON STREET - TYPICAL KERB CUTOUT SECTIONS** 8  
8



DYBD REQUIRED BEFORE ALL WORKS COMMENCE

**FINISHED DRAWING**  
FOR DISCUSSION PURPOSES ONLY  
SUBJECT TO FURTHER AMENDMENT  
SIGNED RACHAEL GADD  
DATE 26-MARCH-2023

REV	DATE	COMMENT	INITIALS
REVA	23/05/22	TENDER ISSUE	CM
REVB	26/03/23	CONSTRUCTION ISSUE	CM

**towongshire**  
Innovation : technology : sustainability  
32 TOWONG STREET [PO BOX 55]  
TALLANGATTA VIC 3700  
02 6071 5100  
WWW.TOWONG.VIC.GOV.AU

**TOWONG SHIRE COUNCIL**  
OMEO\_HIGHWAY  
MITTA\_MITTA VIC 3701  
MITTA\_MITTA\_PATHWAYS\_AND\_INFRASTRUCTURE  
TYPICAL\_SECTIONS\_SHEET\_5\_OF\_5

DESIGNED	CM	DRAWING NO	
DRAWN	CM	T210809	
CHECKED	RG		
APPROVED	RG	SHEET NO	PAGE SIZE
SCALE	1:250	18	A3
UNIT	METRES		